

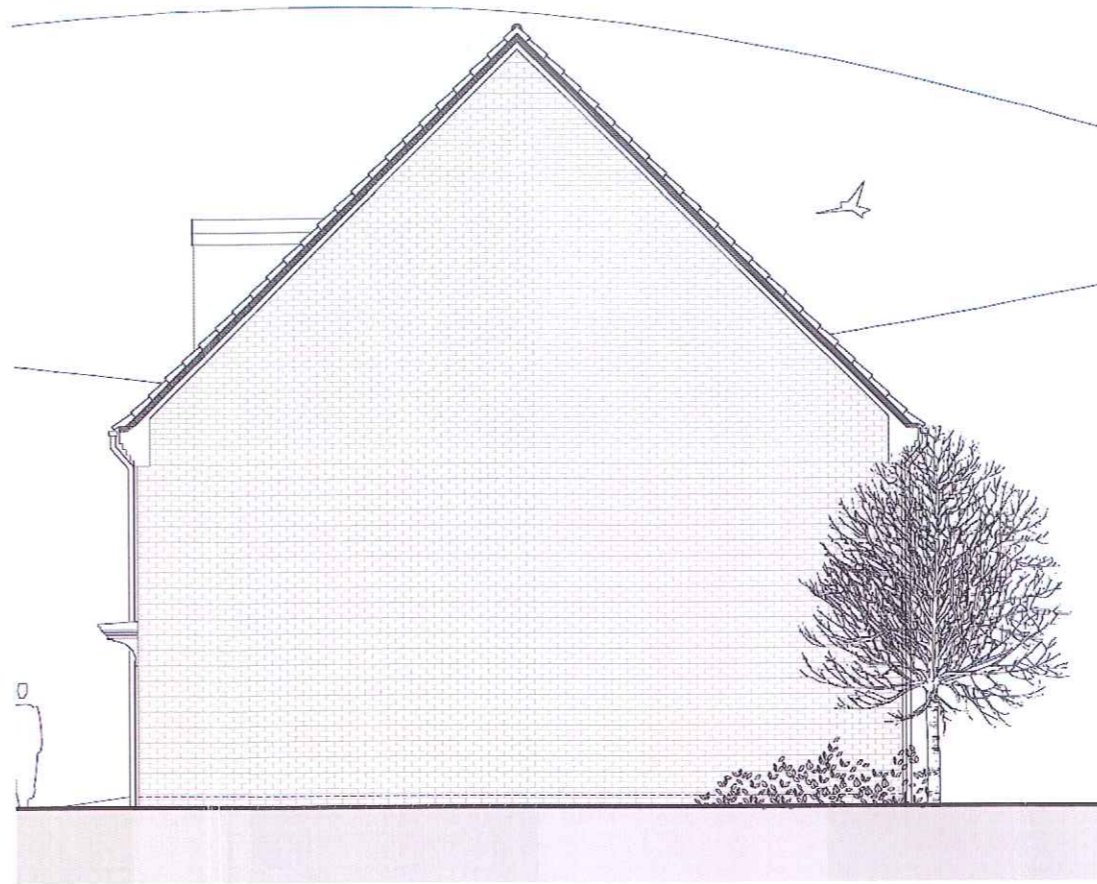

Front Elevation



Side Elevation



Rear Elevation

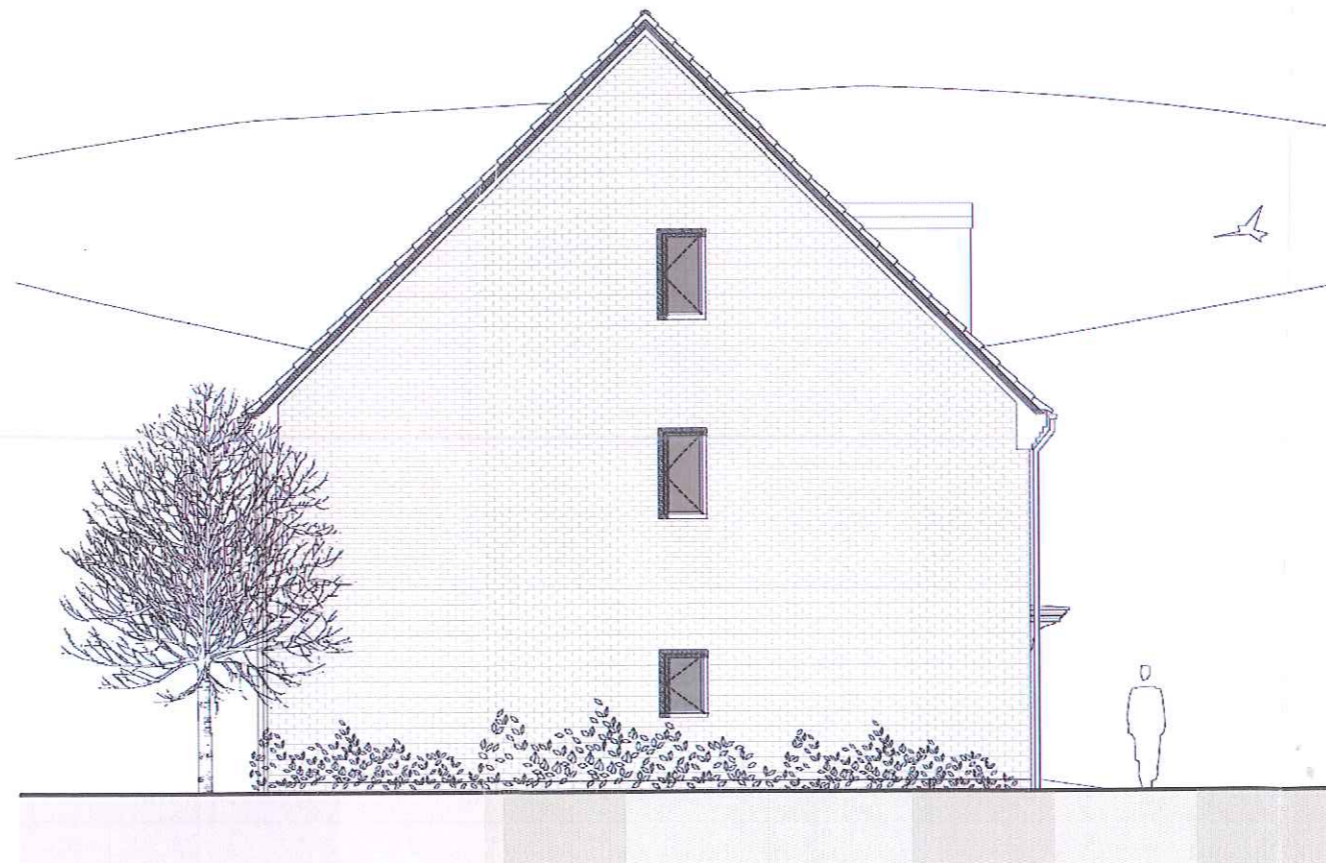

Side Elevation

2012/275

06 JUL 2012

revision date drawn description

Taylor Wimpey
 Holcombe Road
ELEVATIONS H1089 BRICK RED
 04.05.12 SM 1:100 @ A3
10082 (PI) 234 *

calderpeel architects
 market court, 20-24 church street
 alltrincham, cheshire, WA14 4DW
 t.0161 929 7622 f.0161 929 7655

calderpeel

www.calderpeel.com

Rear Elevation

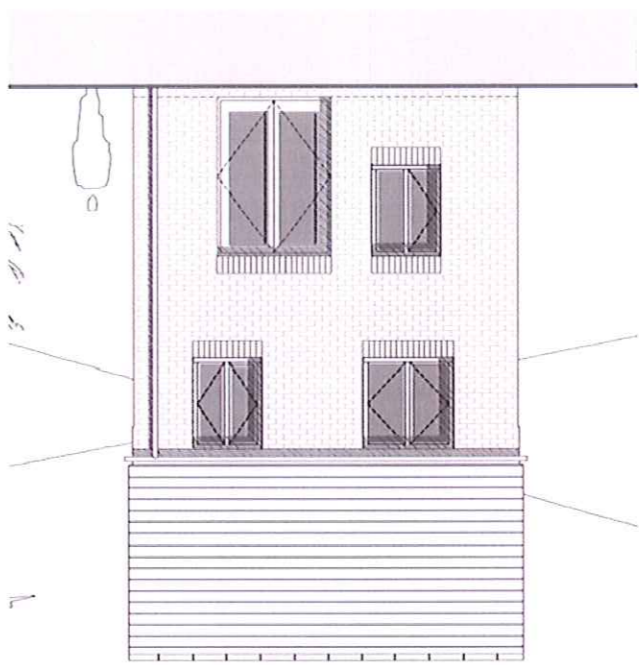

Front Elevation

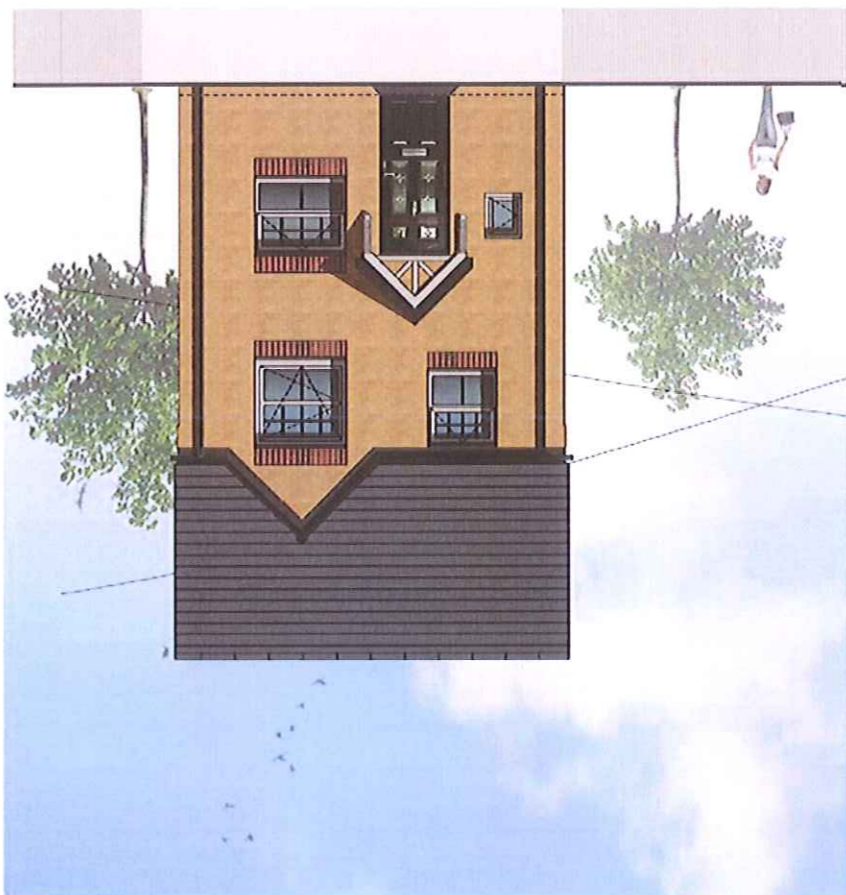

Side Elevation

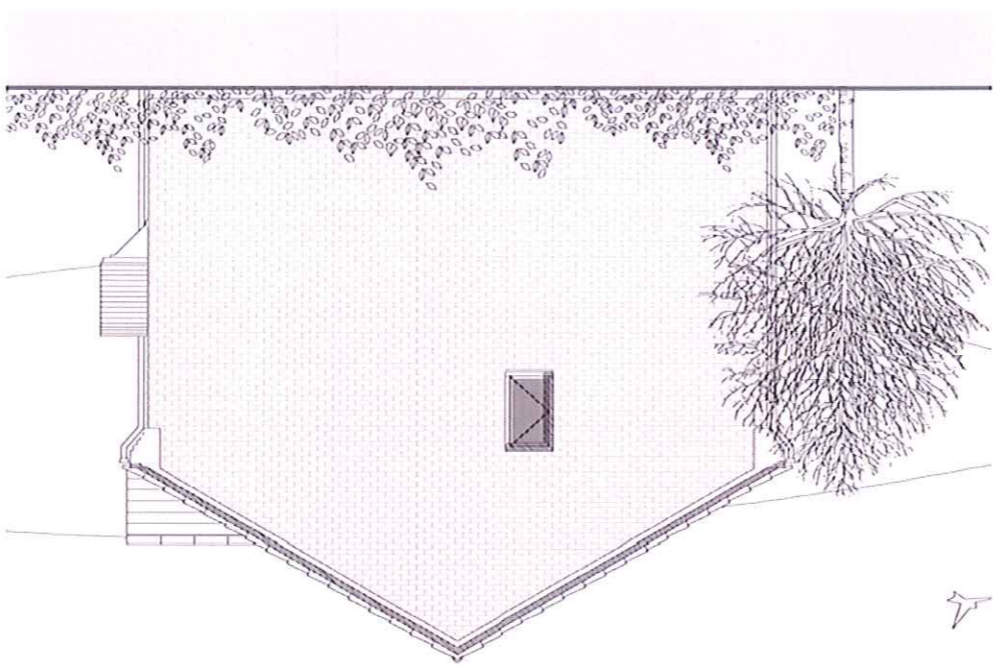

Side Elevation

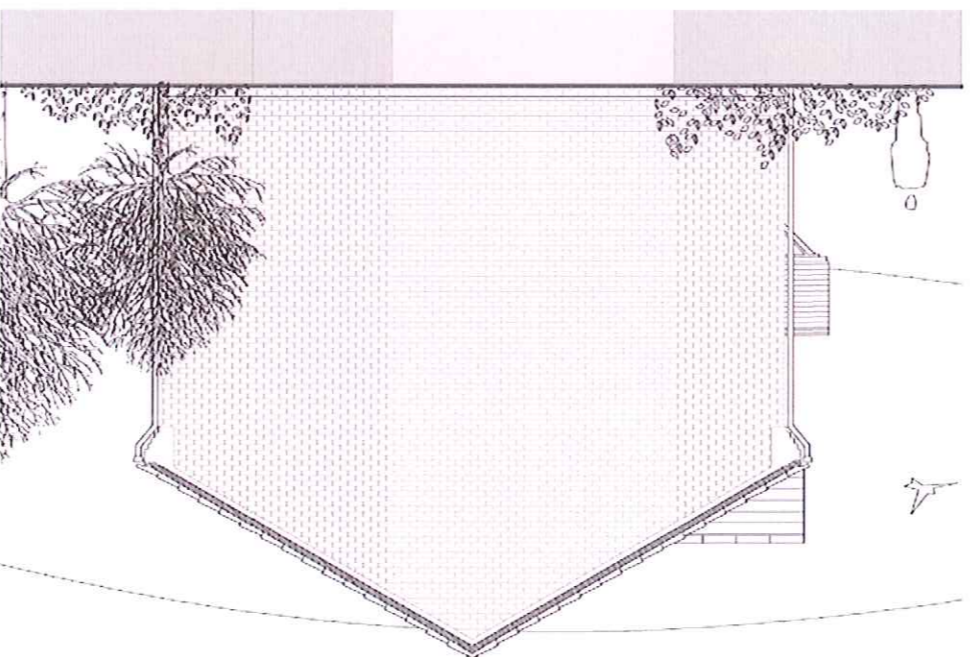

calderpeel architects
market court, 20-24 church street
allitocham, cheshire, WA14 4DW
1.0161 929 7622 1.0161 929 7655

Taylor Wimpey
Holcombe Road
ELEVATIONS H745 BRICK BUFF
02.05.12 CP 1:100 @ A3
10082 (PI) 226 *

06 JUL 2012

revision date drawn description

www.calderpeel.com

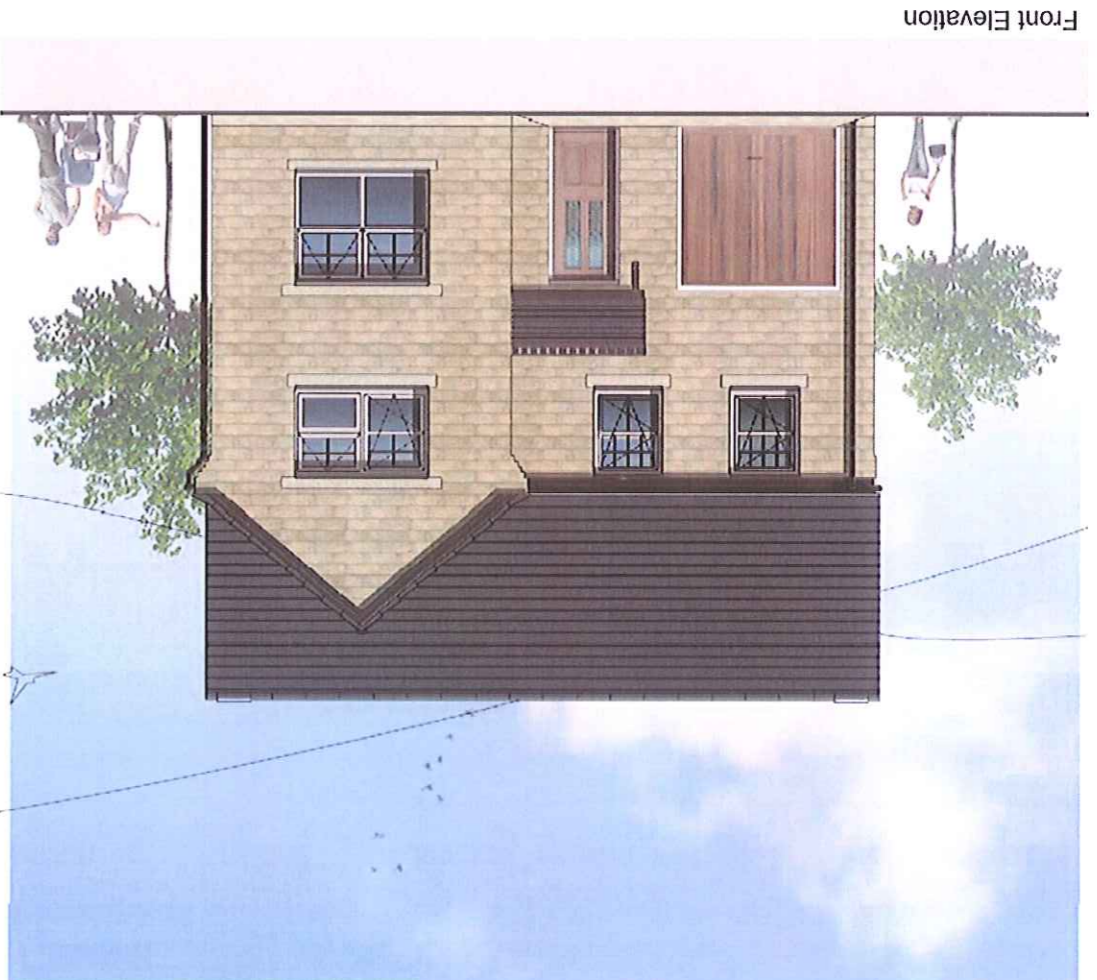

Front Elevation

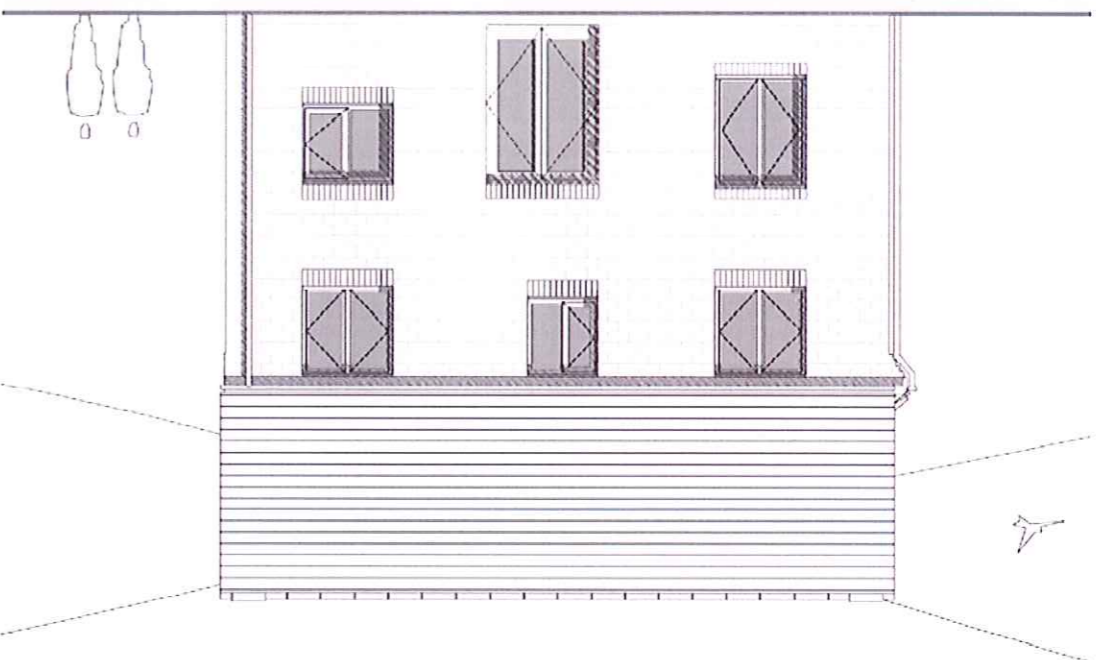

Rear Elevation

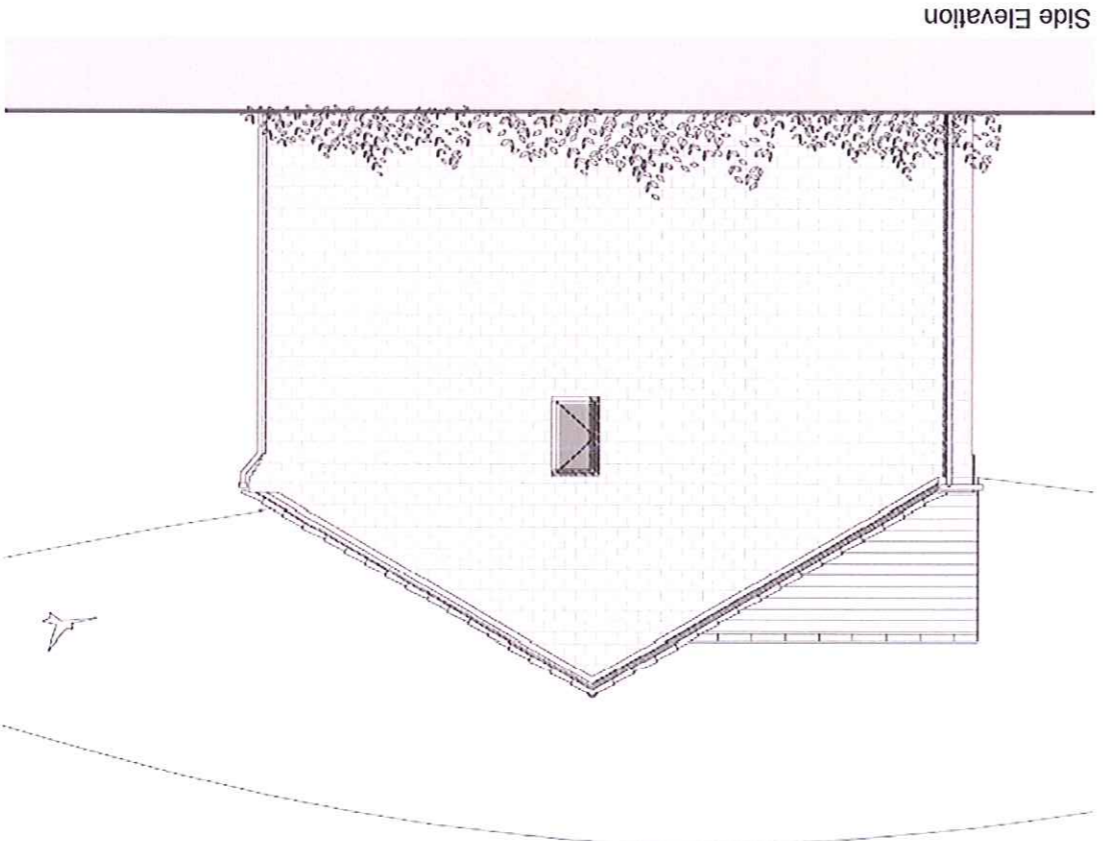

Side Elevation

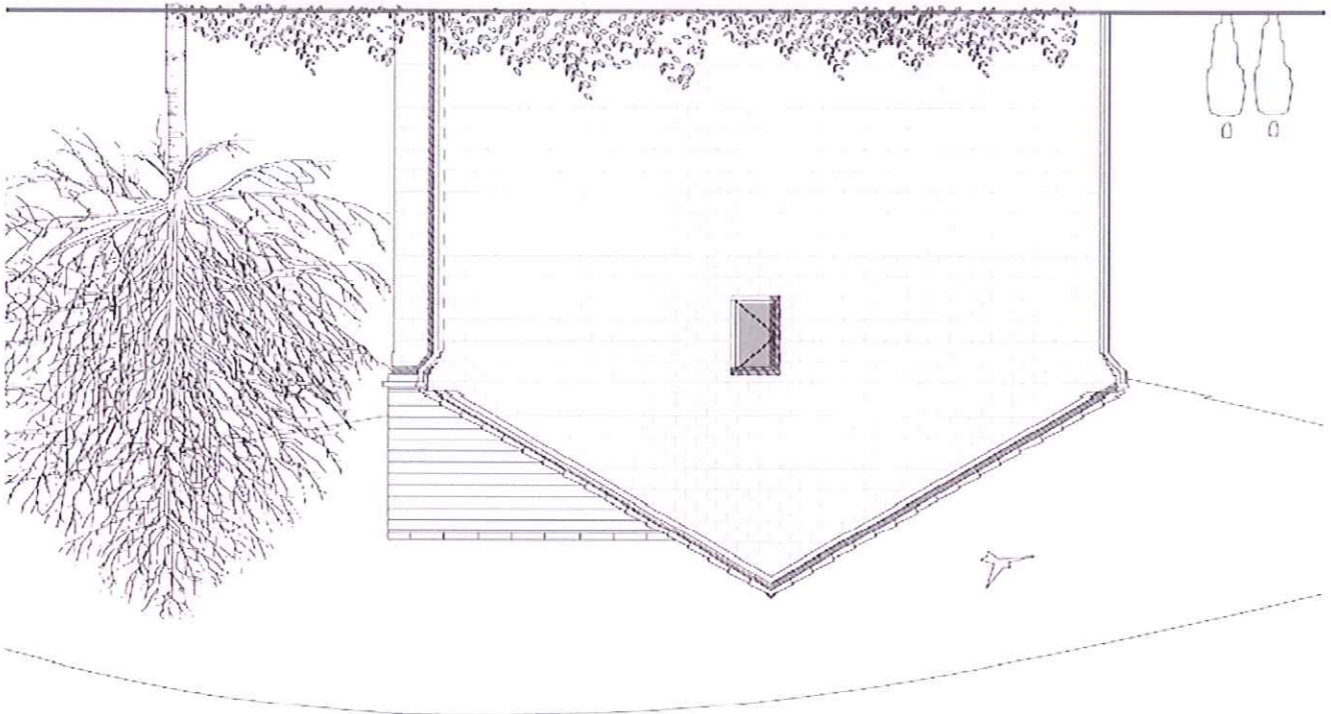

Side Elevation

revision	date	drawn	description

calderpeel architects
 market court, 20-24 church street
 altonham, cheshire, WA14 4DW
 1.0161 929 7622 1.0161 929 7655

Taylor Wimpey
 Holcombe Road

ELEVATIONS PD410 ART STONE

02.05.12 CP 1:100 @ A3
10082 (PI) 232 *

www.calderpeel.com

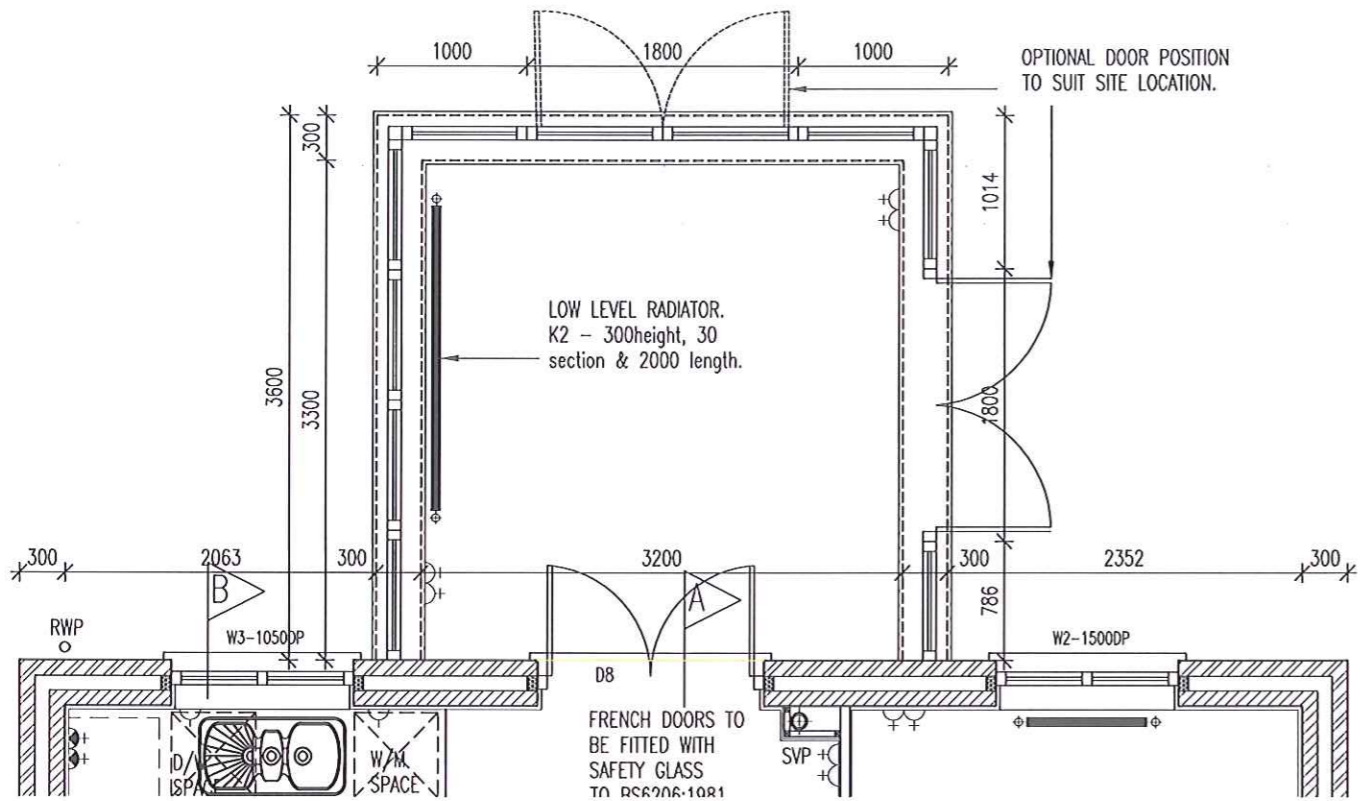

GROUND FLOOR PLAN 1:50

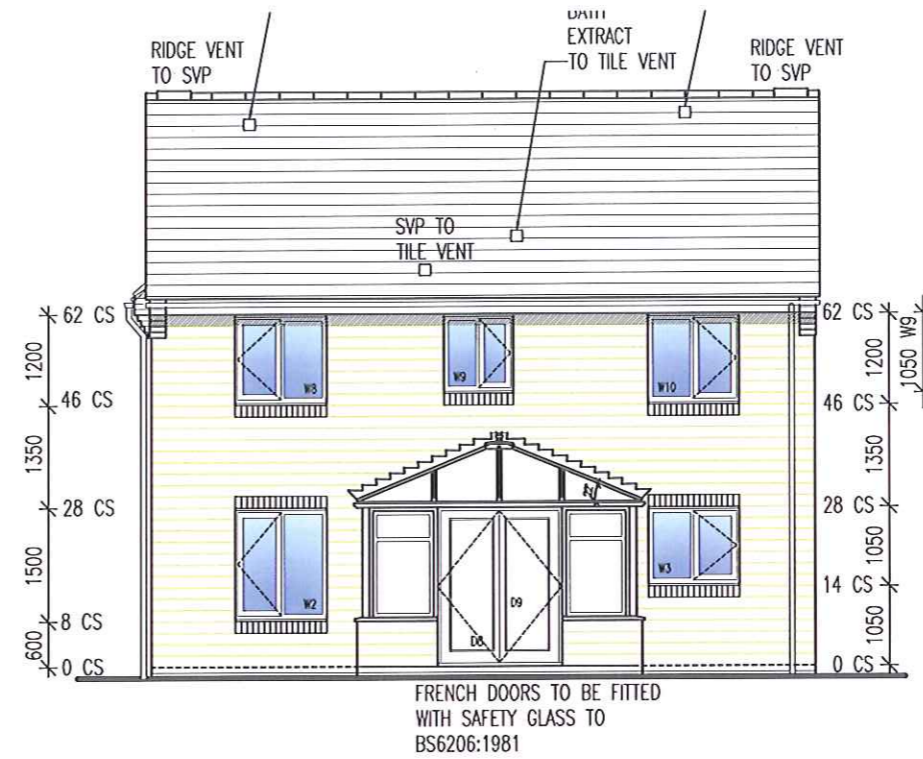

REAR ELEVATION 1:100

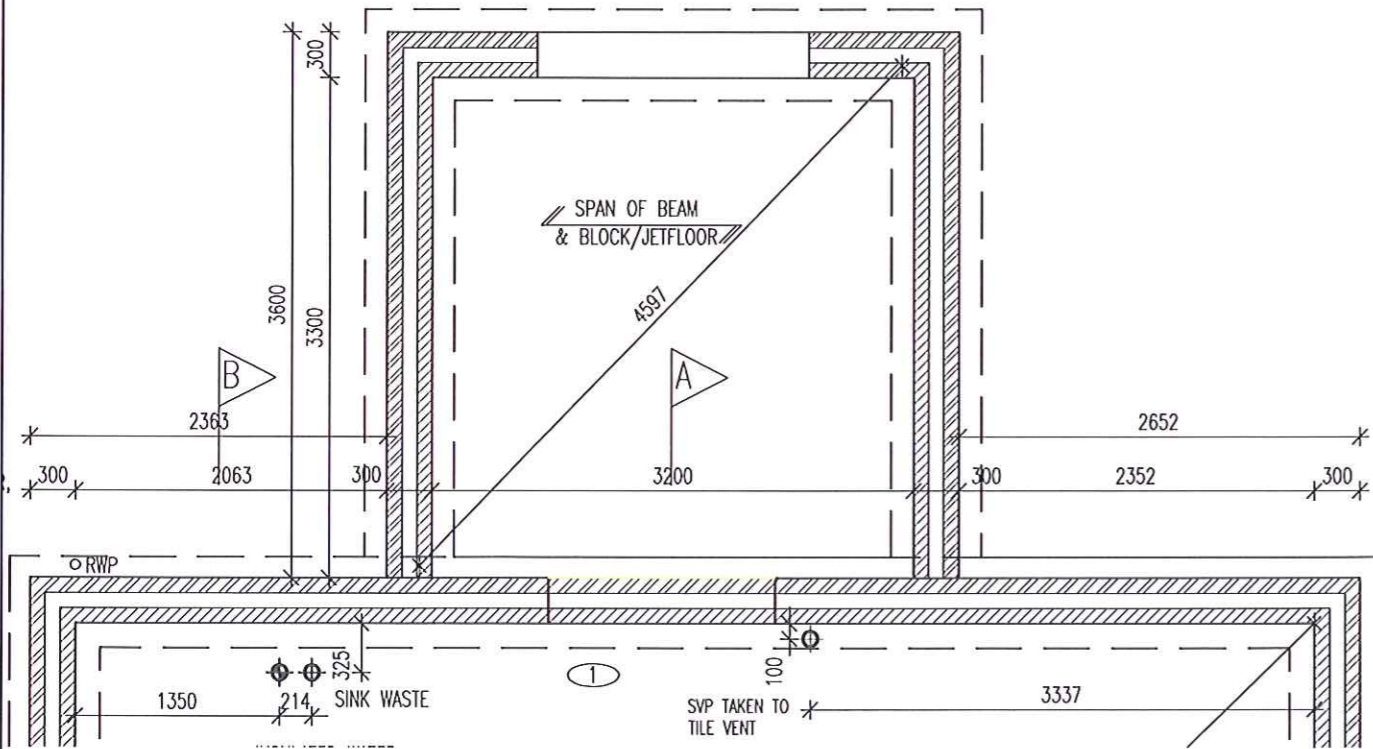

FOUNDATION PLAN 1:50

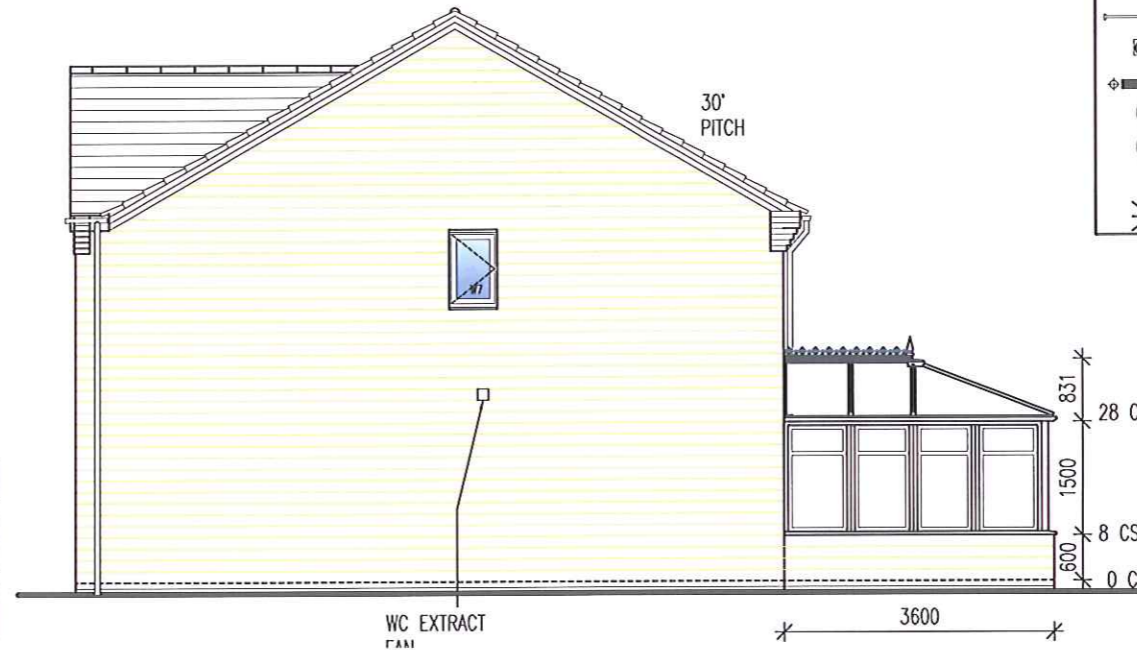

SIDE ELEVATION 1:100

SYMBOL	DESCRIPTION
	13 AMP. TWIN SWITCHED SOCKET OUTLET
	13 AMP. SWITCHED SOCKET OUTLET
	13 AMP. SOCKET OUTLET
	13 AMP. TWIN SWITCHED SOCKET OUTLET ABOVE WORKTOP
	13 AMP. SWITCHED SOCKET OUTLET ABOVE WORKTOP
	MULTI GRID SWITCH ABOVE WORKTOP CONTROLLING UNSWITCHED SOCKETS BELOW WORKTOP
	13 AMP. SPUR UNIT
	13 AMP. SWITCHED SPUR UNIT
	ONE WAY SWITCH
	TWO WAY SWITCH
	TIMER SWITCH
	TELEPHONE POINT
	TELEVISION POINT
	COOKER SWITCH (1100MM ABOVE FFL)
	CONSUMER SERVICE UNIT
	SHAVER POINT AS SITE SPEC
	CEILING LIGHTING POINT - PENDANT TYPE
	CEILING LIGHTING POINT - BATTEN TYPE
	RECESSED SPLASHPROOF DOWNLIGHTER
	DOWN LIGHTERS SEE COMPANY SPECIFICATION
	CEILING LIGHTING POINT WITH ENERGY EFFICIENT FITTING
	WALL MOUNTED LIGHTING POINT
	CEILING MOUNTED BULKHEAD FITTING
	SPLASHPROOF IP44 LAMP FITTING
	CENTRAL HEATING PROGRAMMER AT BOILER ON LOW PRESSURE SYSTEM - INTEGRAL IN BOILERMATE UNIT ON MAINS PRESSURE SYSTEM
	ROOM THERMOSTAT
	EXTRACT FAN
	3 POLE ISOLATOR SWITCH FOR EXTRACT MARKED WITH FAN SYMBOL
	FLUORESCENT LIGHT FITTING
	CENTRAL HEATING WIRING JUNCTION BOX
	RADIATOR
	SMOKE DETECTOR
	HEAT DETECTOR
	GAS POINT
	SHOWER HEAD

Taylor Wimpey

Title: EYNESHAM
 STANDARD HOUSING RANGE ISSUE 3
 GENERAL ARRANGEMENT
 CONSERVATORY OPTION
 Holcombe Road, Helmshore

Ref: PD41/ 3 /100 -

Scale: 1 : 50 @ A3 Date: MAY 2012

Drawn By: ABA Checked By: PT

Taylor Wimpey UK Ltd
 Gate House, Tumpkett Road,
 High Wycombe, Bucks HP12 3NR
 Tel 01494 558323 Fax 01494 885663
 www.taylorwimpey.com

06 JUL 2012

20 12 / 275

GROUND FLOOR

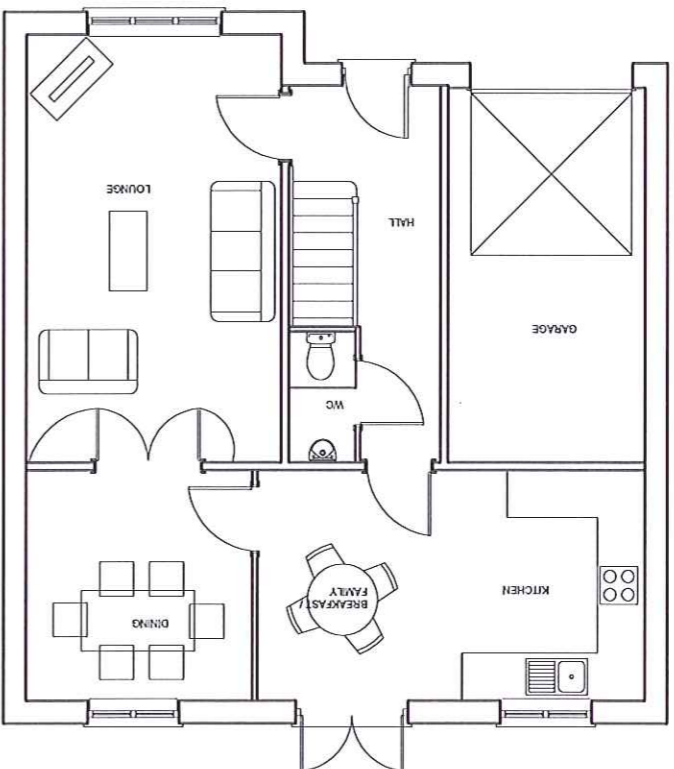

FIRST FLOOR

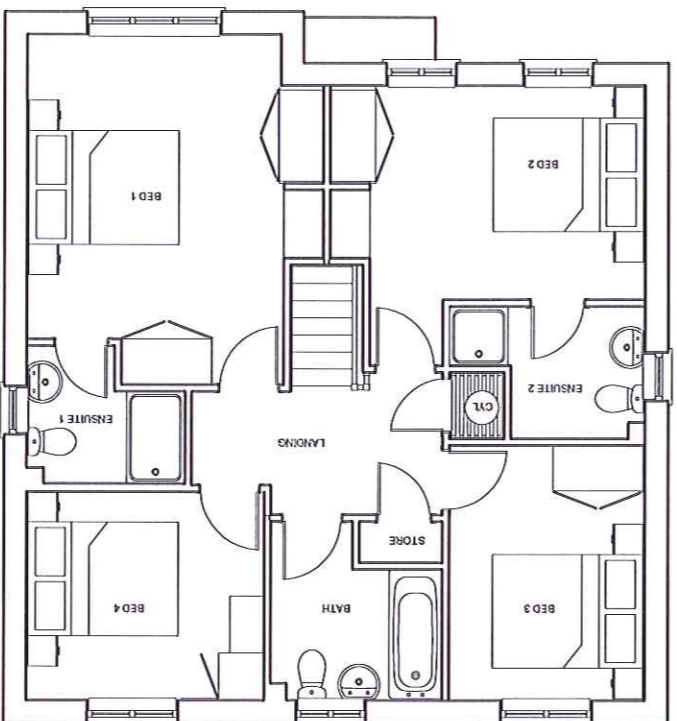

0 6 JUL 2012

revision	date	drawn	description

calderpeel architects
 market court, 20-24 church street
 alfrincham, cheshire, WA14 4DW
 1.0161 929 7622 1.0161 929 7655

Taylor Wimpey
 Holcombe Road
PLANS PD 410
 20.02.12 LF 1:100 @ A3
10082 (PI) 116 *

GROUND FLOOR

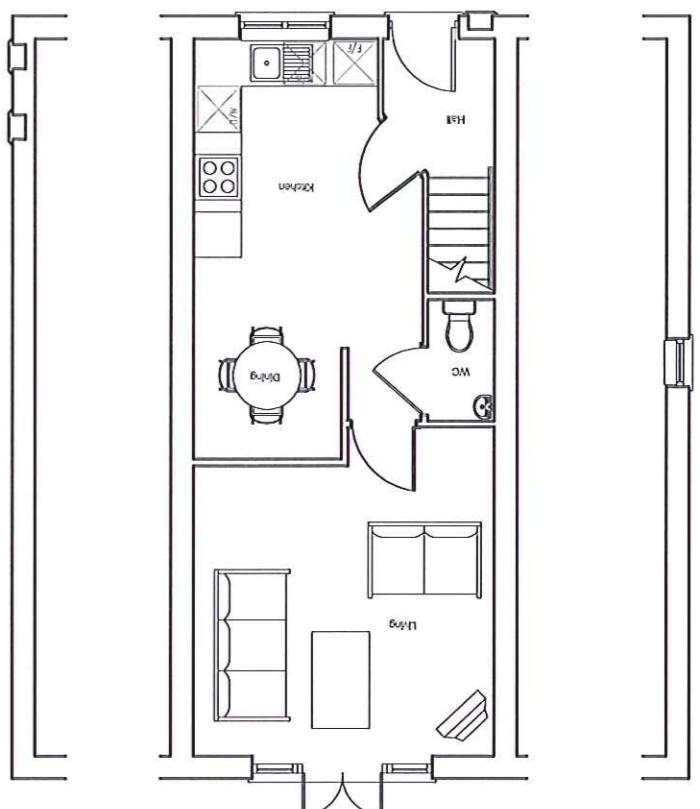

FIRST FLOOR

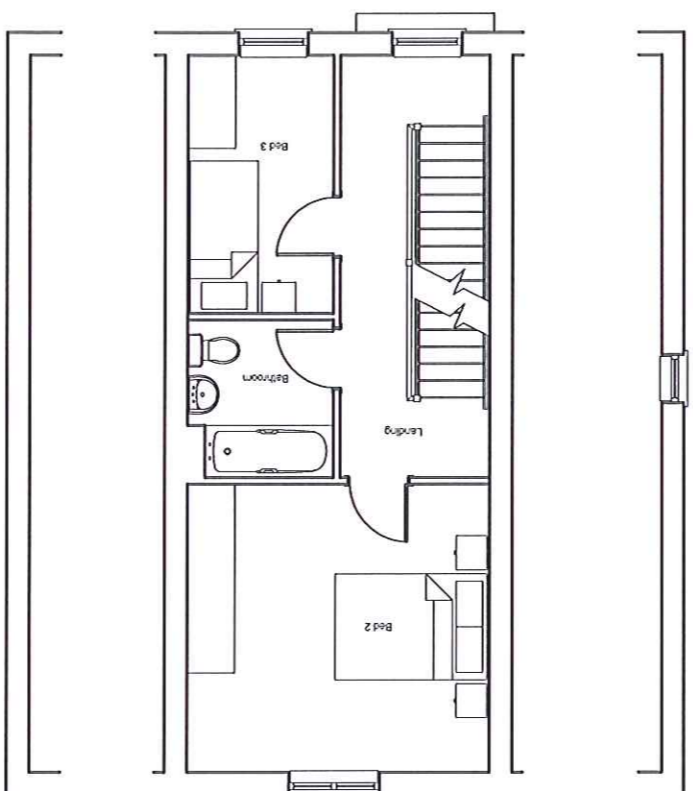

SECOND FLOOR

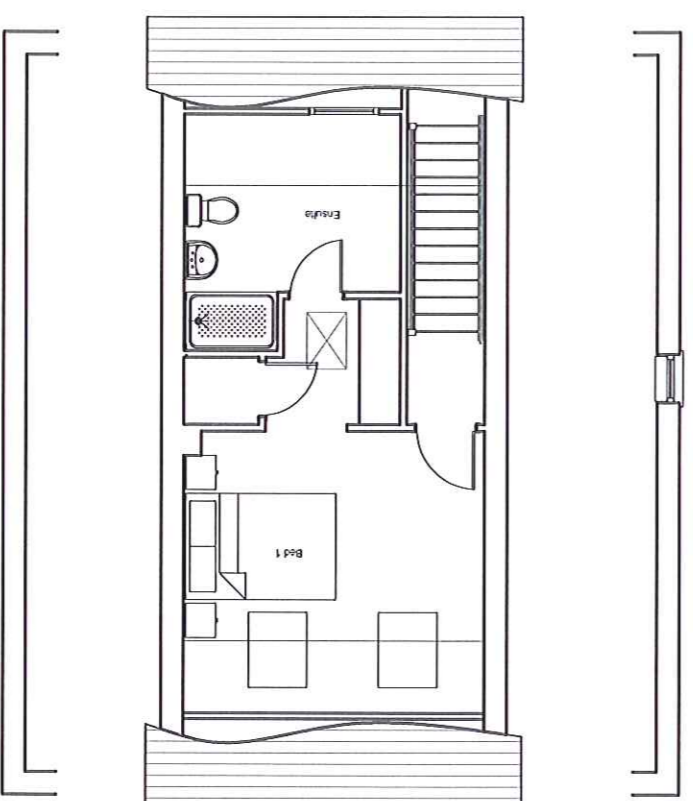

calderpeel architects
 calderpeel architects
 market court, 20-24 church street
 altrincham, cheshire, WA14 4DW
 1.0161 929 7622 1.0161 929 7655

Taylor Wimpey
 Holcombe Road
PLANS H1089
 03.05.12 CP 1:100 @A3
10082 (PI) 115 A

06 JUL 2012

revision	date	drawn	description
A	03.05.12	CP	plans amended

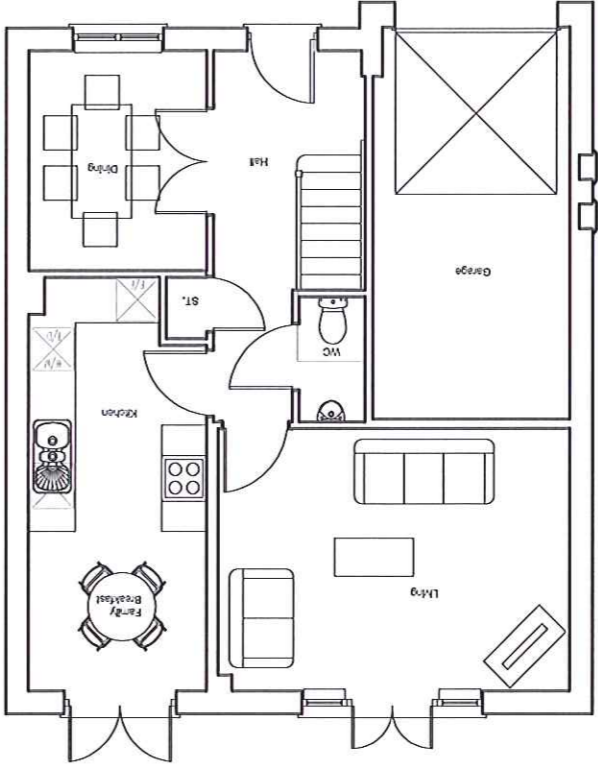

GROUND FLOOR

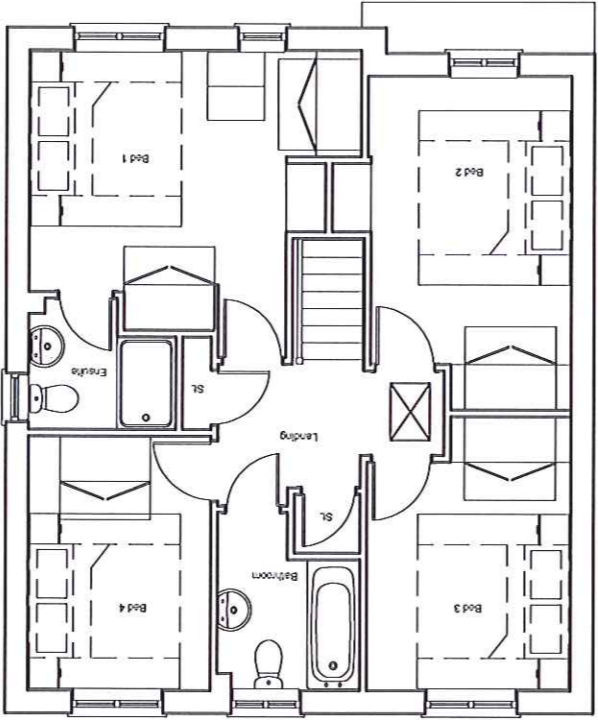

FIRST FLOOR

2012/275

06 JUL 2012

revision date drawn description

Taylor Wimpey
Holcombe Road

PLANS PD 48

02.05.12 CP 1:100 @A3

10082 (PJ) 118 *

www.calderpeel.com

calderpeel architects
market court, 20-24 church street
altrincham, cheshire, WA14 4DW
10161 929 7622 10161 929 7655

2012/275
 06 JUL 2012

GROUND FLOOR

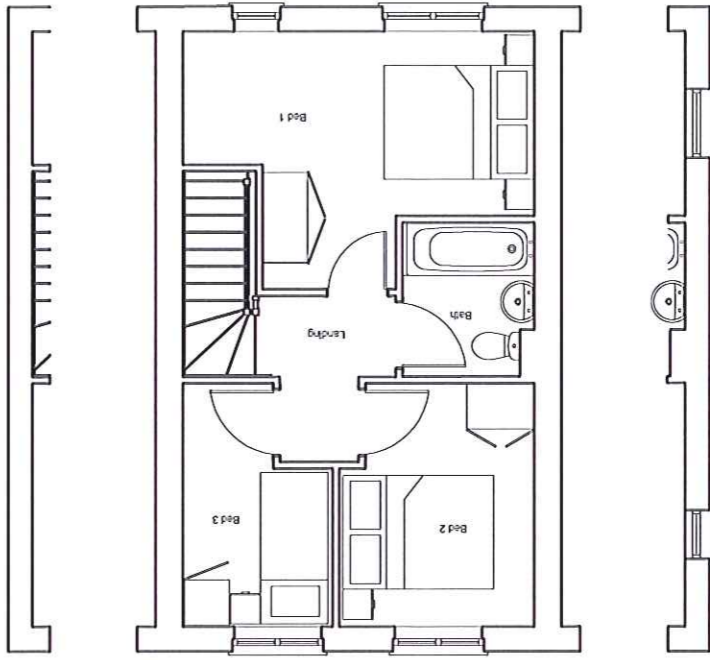

FIRST FLOOR

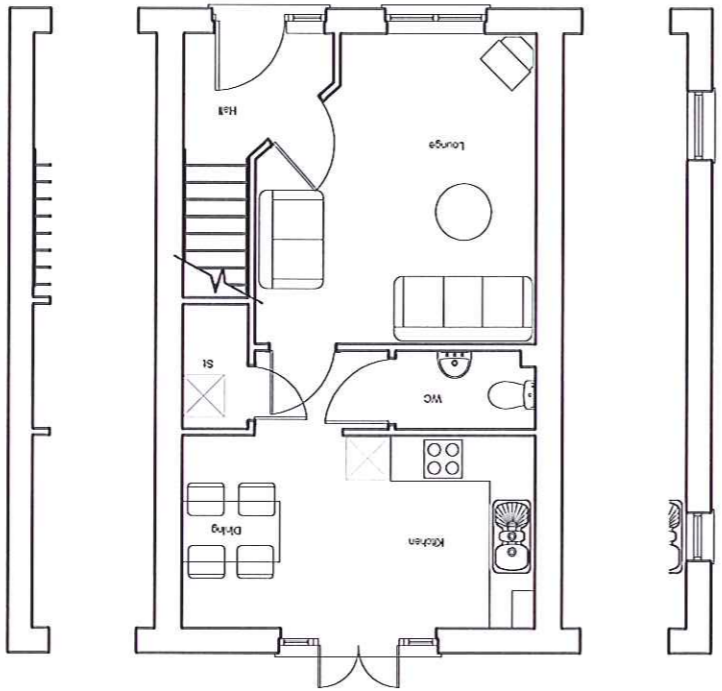

revision date drawn description

Taylor Wimpey
 Holcombe Road
PLANS PA32
 18.05.12 MM 1:100 @ A3
10082 (P1) 119 *

calderpeel architects
 market court, 20-24 church street
 allinham, cheshire, WA14 4DW
 1.0161 929 7622 1.0161 929 7655
 calderpeel

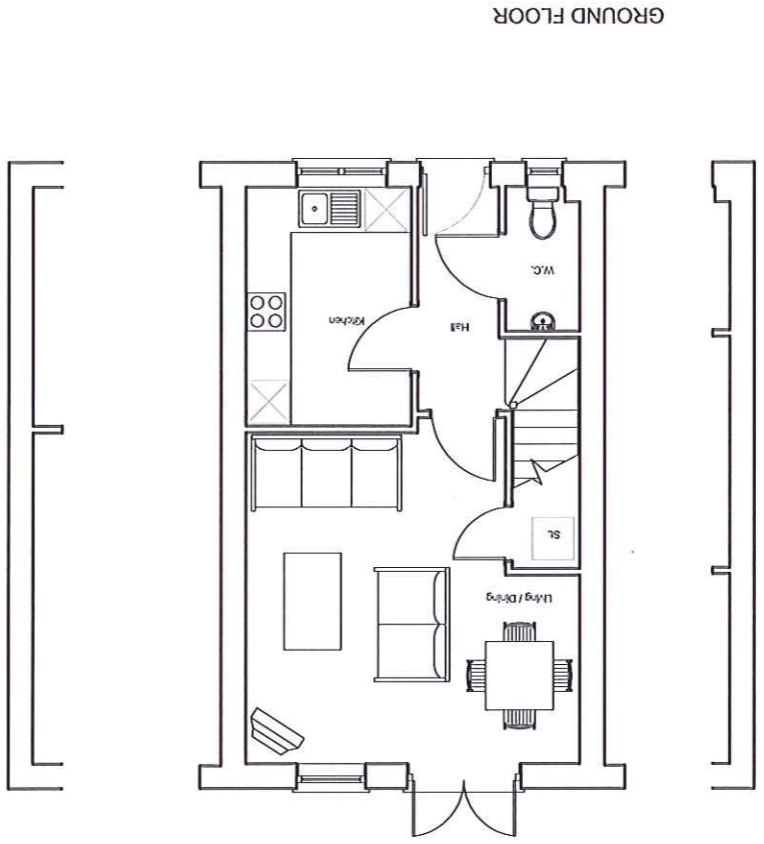

GROUND FLOOR

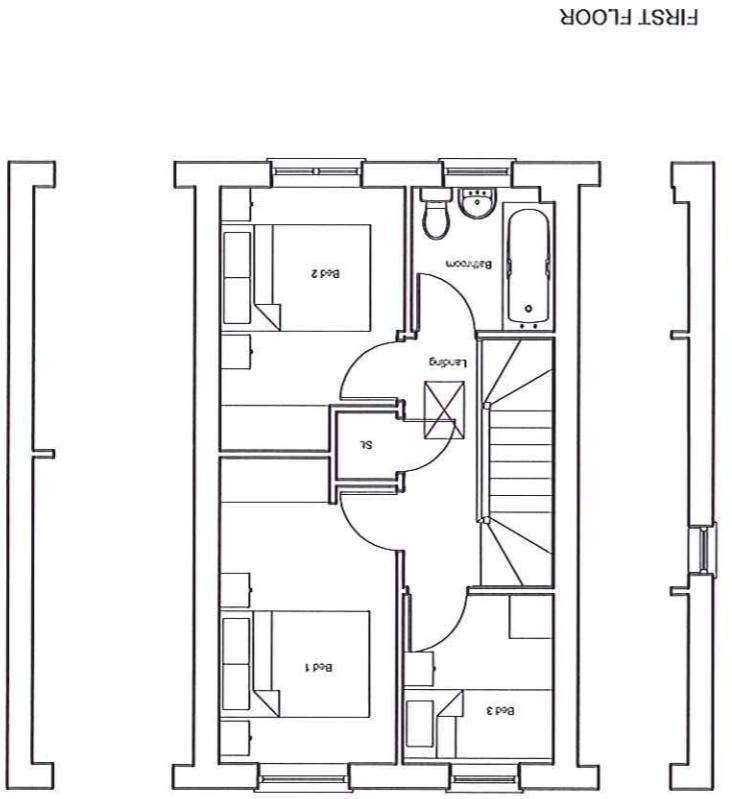

FIRST FLOOR

revision	date	drawn	description

0 6 JUL 2012

calderpeel architects
 market court, 20-24 church street
 allinham, cheshire, WA14 4DW
 1.0161 929 7622 1.0161 929 7655

Taylor Wimpey
 Holcombe Road
PLANS H 745
 02.05.12 CP 1:100 @ A3
10082 (PI) 117 *

www.calderpeel.com

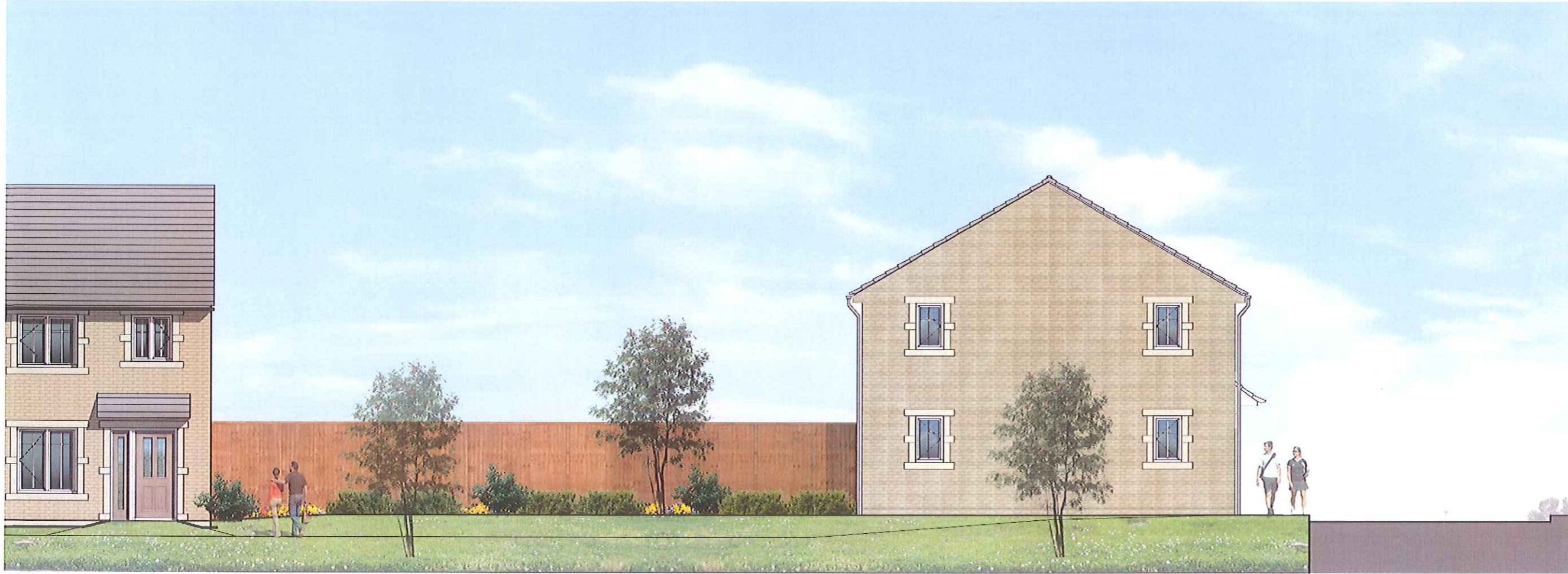

Plot 61 House Type PA32 Art Stone River Front Elevation

2012/275

06 JUL 2012

revision date drawn description

Taylor Wimpey
Holcombe Road

Plot 61(PA32 House Type) Side Elevation

08.10.10 LK 1:100 @ A3

10082 (PI) 290 *

calderpeel architects
market court, 20-24 church street
alltrincham, cheshire, WA14 4DW
t.0161 929 7622 f.0161 929 7655

calderpeel

www.calderpeel.com